

RETAINING COMPONENTS INDEX

PAGE	DATE	SERIES	DESCRIPTION
R-1	06/02/04		Retaining Components Index
R-2	01/18/99	R01	Keeper Blocks For Pads (6 mm Lip M12 Screws)
R-3	04/16/96	R01	Keeper Blocks For Pads (6 mm Lip M12 Screws) Coding
R-4	08/12/97	R02	Keeper Blocks For Pads (13 mm Lip M16 Screws)
R-5	01/03/95	R02	Keeper Blocks For Pads (13 mm Lip M16 Screws) Coding
R-6	08/12/97	R11	Self-Lube Cam Gibs (13 mm Lip M12 Screws)
R-7	08/12/97	R12	Self-Lube Cam Gibs (10 mm Lip M16 Screws)
R-8	04/30/14	R21 & R22	Self-Lube Gib Plates
R-9	06/02/04	R32	Spool Type Pad Retainers
R-10	08/12/97	R41 & R43	Pad Retaining Pin
R-11	08/12/97	R42	Pad Standby/Lock Pin

KEEPER BLOCKS FOR PADS

(R01 SERIES)

6 mm LIP M12 SCREWS

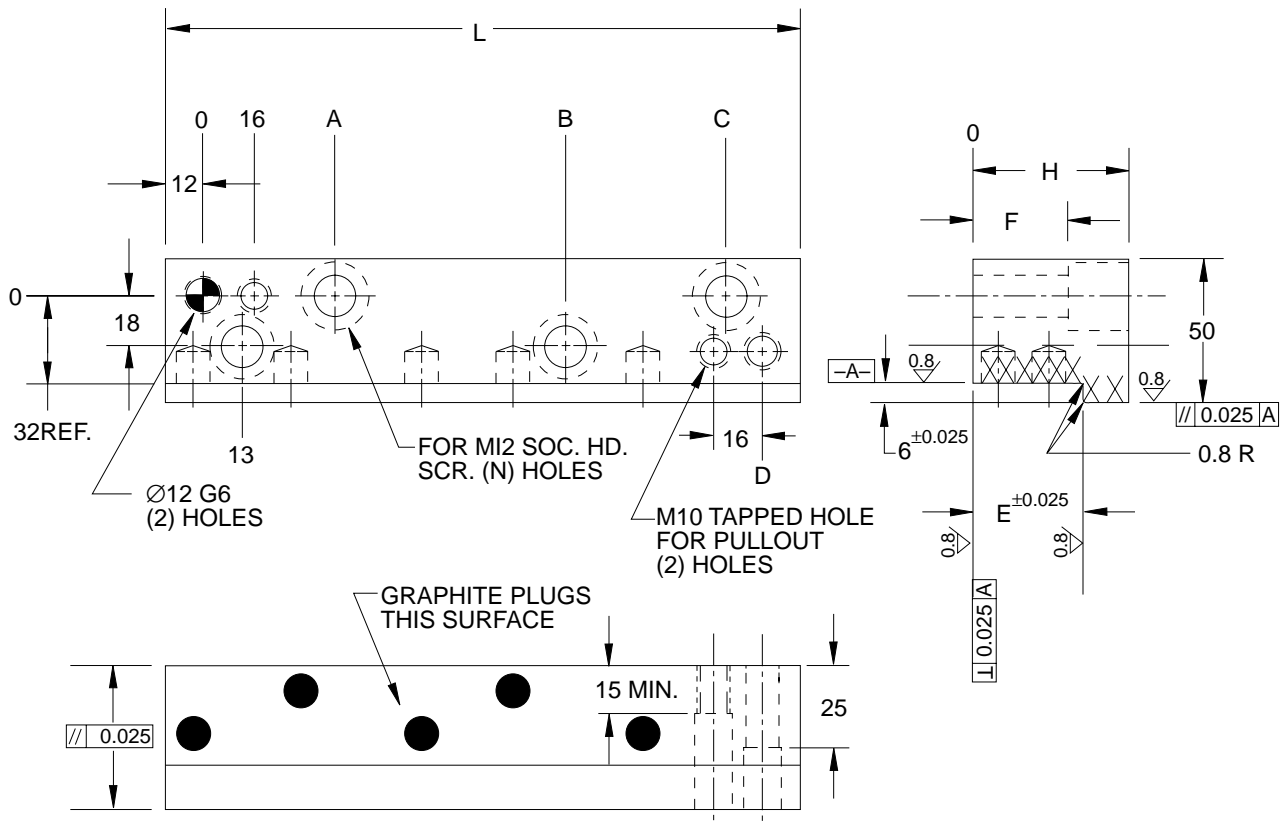

NOTES & SPECIFICATIONS:

Screw hole locations ± 0.25

Dowel hole locations ± 0.10

Break all sharp edges $0.4 \times 45^\circ$

Material, steel

Surface harden cross-hatched areas.

Evenly distributed graphite plugs to cover 20-30% of the area that requires lubrication

KEEPER BLOCKS FOR PADS CODING

(R01 SERIES)



Stamping

04/16/96

6 mm LIP M12 SCREWS

NAAMS CODE	(N) HOLES	L	A	B	C	D	E	F	H
R012507	2	75	-	-	38	51	25	15	37
R012510	2	100	-	-	63	76			
R012515	3	150	-	63	113	126			
R012520	4	200	63	113	163	176			
R013207	2	75	-	-	38	51	32	15	45
R013210	2	100	-	-	63	76			
R013215	3	150	-	63	113	126			
R013220	4	200	63	113	163	176			
R013707	2	75	-	-	38	51	37	30	50
R013710	2	100	-	-	63	76			
R013715	3	150	-	63	113	126			
R013720	4	200	63	113	163	176			
R014810	2	100	-	-	63	76	48	30	60
R014815	3	150	-	63	113	126			
R014820	4	200	63	113	163	176			
R014825	4	250	83	153	213	226			

KEEPER BLOCKS FOR PADS

(R02 SERIES)

13 mm LIP M16 SCREWS

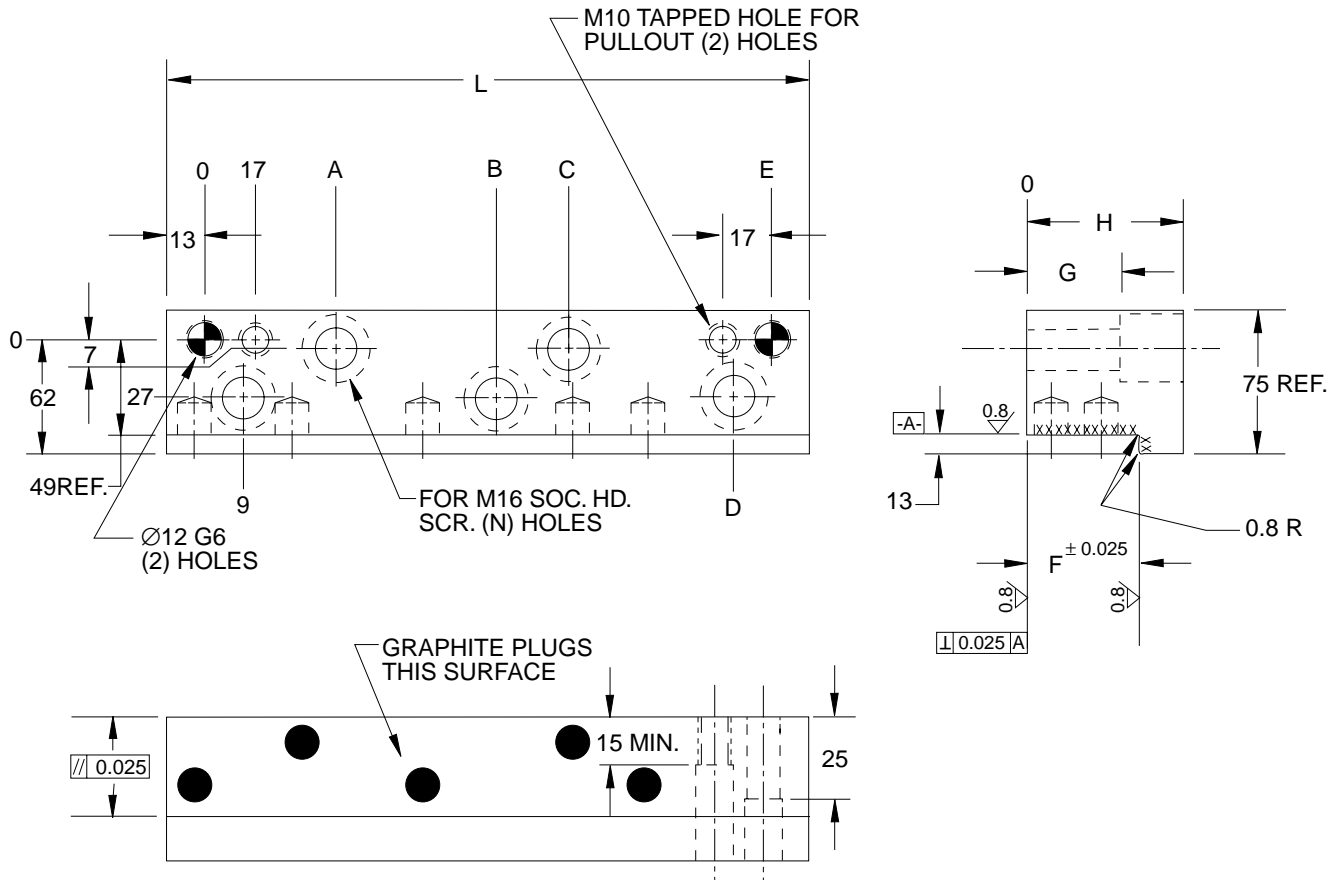

NOTES & SPECIFICATIONS:

Screw hole locations ± 0.25

Dowel hole locations ± 0.10

Break all sharp edges $0.4 \times 45^\circ$

Material, steel

Surface harden cross-hatched areas.

Evenly distributed graphite plugs to cover 20-30% of the area that requires lubrication

KEEPER BLOCKS FOR PADS CODING

(R02 SERIES)



Stamping

01/03/95

13 mm LIP M16 SCREWS

NAAMS CODE	(N) HOLES	L	A	B	C	D	E	F	G	H
R023510	2	100	-	-	-	65	74	35	25	50
R023512	3	125	49.5	-	-	90	99			
R023515	3	150	62	-	-	115	124			
R023520	4	200	62	-	112	165	174			
R023522	5	225	62	99.5	137	190	199			
R023525	5	250	62	112	162	215	224			
R023530	5	300	62	137	212	265	274			
R024010	2	100	-	-	-	65	74	40	25	60
R024012	3	125	49.5	-	-	90	99			
R024015	3	150	62	-	-	115	124			
R024020	4	200	62	-	112	165	174			
R024022	5	225	62	99.5	137	190	199			
R024025	5	250	62	112	162	215	224			
R024030	5	300	62	137	212	265	274			
R025010	2	100	-	-	-	65	74	50	30	70
R025012	3	125	49.5	-	-	90	99			
R025015	3	150	62	-	-	115	124			
R025020	4	200	62	-	112	165	174			
R025022	5	225	62	99.5	137	190	199			
R025025	5	250	62	112	162	215	224			
R025030	5	300	62	137	212	265	274			
R025510	2	100	-	-	-	65	74	55	35	80
R025512	3	125	49.5	-	-	90	99			
R025515	3	150	62	-	-	115	124			
R025520	4	200	62	-	112	165	174			
R025522	5	225	62	99.5	137	190	199			
R025525	5	250	62	112	162	215	224			
R025530	5	300	62	137	212	265	274			
R026510	2	100	-	-	-	65	74	65	45	90
R026512	3	125	49.5	-	-	90	99			
R026515	3	150	62	-	-	115	124			
R026520	4	200	62	-	112	165	174			
R026522	5	225	62	99.5	137	190	199			
R026525	5	250	62	112	162	215	224			
R026530	5	300	62	137	212	265	274			
R027510	2	100	-	-	-	65	74	75	45	100
R027512	3	125	49.5	-	-	90	99			
R027515	3	150	62	-	-	115	124			
R027520	4	200	62	-	112	165	174			
R027522	5	225	62	99.5	137	190	199			
R027525	5	250	62	112	162	215	224			
R027530	5	300	62	137	212	265	274			

SELF-LUBE CAM GIBS

(R11 SERIES)

Stamping

08/12/97

13 mm LIP M12 SCREWS

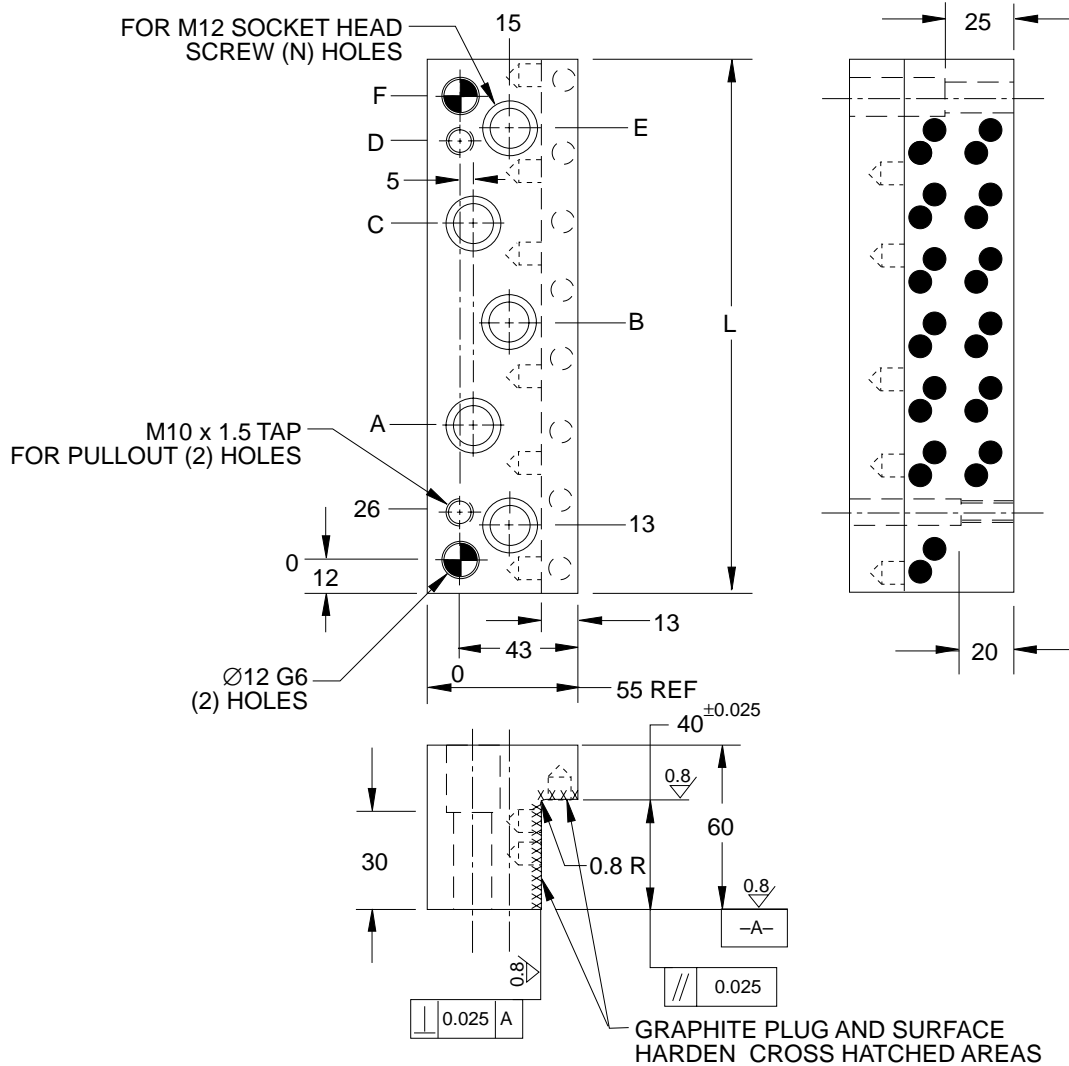

NAAMS CODE	A	B	C	D	E	F	L	(N) HOLES
R114016	68	—	—	110	123	136	160	3
R114020	88	—	—	150	163	176	200	3
R114025	78	—	148	200	213	226	250	4
R114031	78	145.5	213	265	278	291	315	5

NOTES & SPECIFICATIONS:

Screw hole locations ± 0.25

Dowel hole locations ± 0.10

Material, steel

Surface harden cross-hatched areas on steel.

Evenly distributed graphite plugs to cover 20-30% of the area that requires lubrication.

A

SELF-LUBE CAM GIBS

(R12 SERIES)

10 mm LIP M16 SCREWS

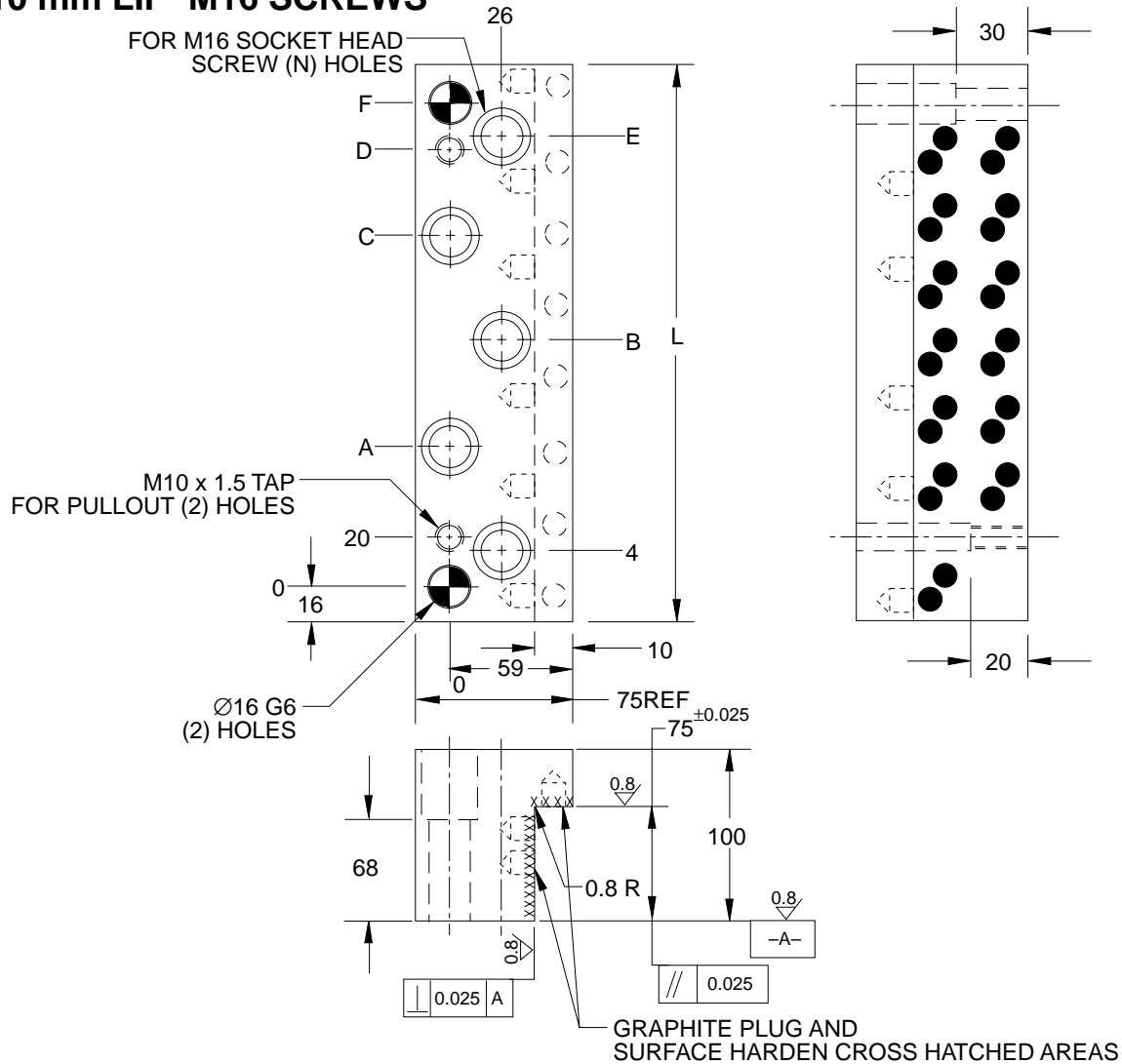

A

NAAMS CODE	A	B	C	D	E	F	L	(N) HOLES
R127516	—	64	—	108	124	128	160	3
R127520	—	84	—	148	164	168	200	3
R127525	74	—	144	198	214	218	250	4
R127531	74	142	210	263	279	283	315	5

NOTES & SPECIFICATIONS:

Screw hole locations ± 0.25

Dowel hole locations ± 0.10

Material, steel

Surface harden cross-hatched areas.

Evenly distributed graphite plugs to cover 20-30% of the area that requires lubrication.

SELF-LUBE GIB PLATES

(R21 & R22 SERIES)

GLOBAL STANDARD COMPONENTS



Stamping

04/30/14

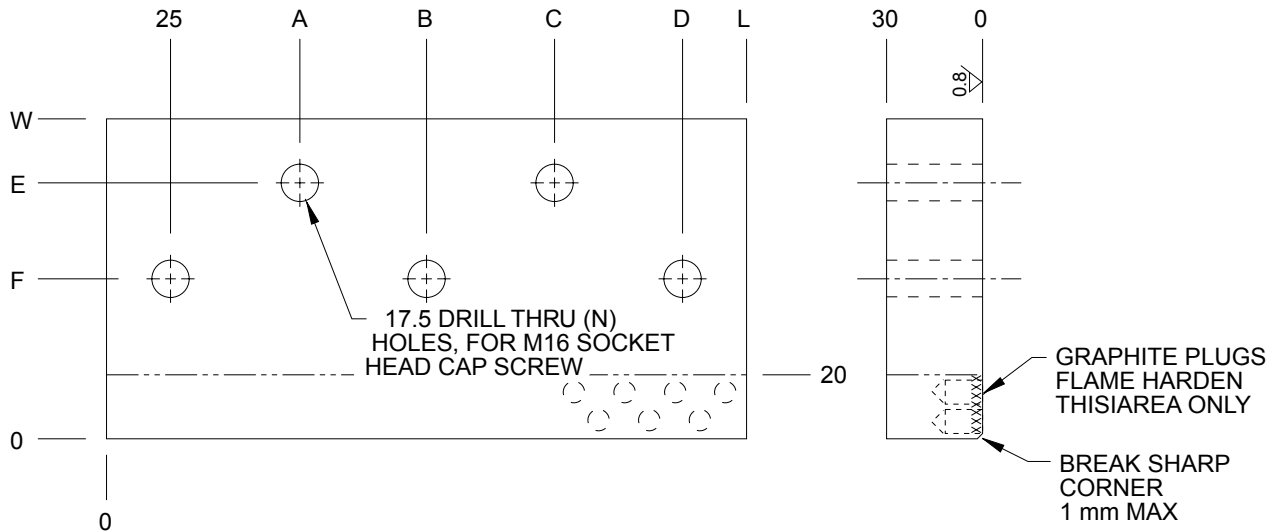

NAAMS CODE DRILLED	NAAMS CODE UNDRILLED	W	L	(N) HOLES	A	B	C	D	E	F
R210720	R220720	75	200	3	100	-	-	175	55	40
R210725	R220725		250		125	-	-	225		
R210731	R220731		315	5	90	158	225	290		
R210735	R220735		350		100	175	250	325		
R210740	R220740		400		115	200	285	375		
R210745	R220745		450		125	225	325	425		
R211020	R221020	100	200	3	100	-	-	175	80	55
R211025	R221025		250	4	90	-	160	225		
R211031	R221031		315	5	90	158	225	290		
R211035	R221035		350		100	175	250	325		
R211040	R221040		400		115	200	285	375		
R211045	R221045		450		125	225	325	425		
R211220	R221220	125	200	3	100	-	-	175	105	65
R211225	R221225		250	4	90	-	160	225		
R211231	R221231		315	5	90	158	225	290		
R211235	R221235		350		100	175	250	325		
R211240	R221240		400		115	200	285	375		
R211245	R221245		450		125	225	325	425		
R211520	R221520	150	200	3	100	-	-	175	130	65
R211525	R221525		250	4	90	-	160	225		
R211531	R221531		315	5	90	158	225	290		
R211535	R221535		350		100	175	250	325		
R211540	R221540		400		115	200	285	375		
R211545	R221545		450		125	225	325	425		

NOTES & SPECIFICATIONS:

Material, steel

Flame harden wear surface

Tolerance between screw holes ±0.25

Evenly distributed graphite plugs to cover 20-30% of the area that requires lubrication.

When CAM return cylinder is mounted to GIB plate then order GIB plate without screw holes.

A

SPOOL TYPE PAD RETAINERS

(R32 SERIES)

GLOBAL STANDARD COMPONENTS



Stamping

06/02/04

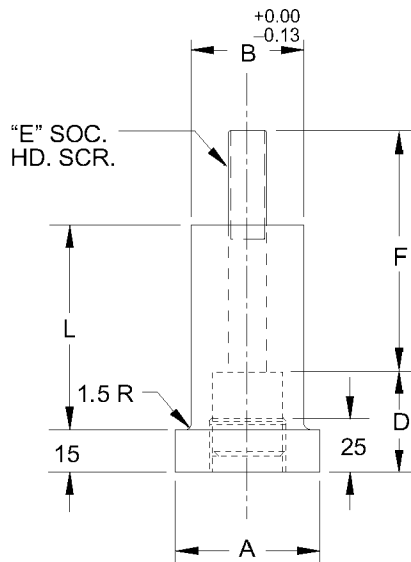
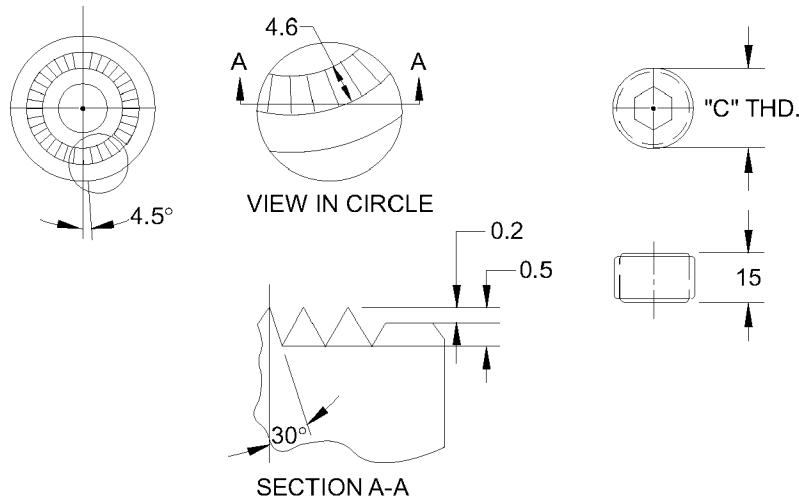

NAAMS CODE	A	B	C	D	E	F	L	TENSILE STRENGTH	
R325030						45	30	192 kN	
R325040						55	40		
R325045						60	45		
R325050						65	50		
R325060						75	60		
R325065						80	65		
R325070	50	40	M27 X2	35	M16 X2	90	70		
R325075						90	75		
R325090						110	90		
R325010						120	100		
R325011						130	115		
R325013						150	130		
R325014						160	140		
R325016						180	160		
R327040						55	40		299 kN
R327045						60	45		
R327050						65	50		
R327060						75	60		
R327065						80	65		
R327070						90	70		
R327075	70	60	M36 X3	40	M20 X2.5	90	75		
R327090						110	90		
R327010						120	100		
R327011						130	115		
R327013						150	130		
R327014						160	140		
R327016						180	160		

NOTES & SPECIFICATIONS:

Material, steel

Socket set screw and socket head cap screw are included in assembly.

A

B

PAD RETAINING PIN

(R41 & R43 SERIES)

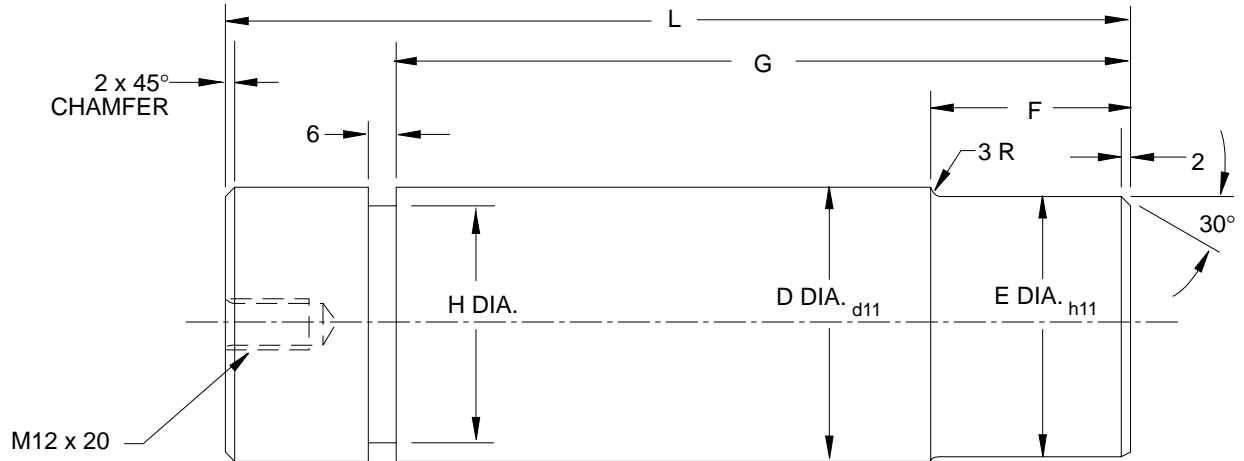

NAAMS CODE	PIN SIZE D	E	F	G	H	L
R412511	25	22	25	75	17	110
R413513	35	32	30	95	27	130
R415017	50	47	35	135	42	170
R416321	63	60	45	170	55	210

NOTES & SPECIFICATIONS:

Tensile strength 965 MPa (140 ksi).

Yield strength 860 MPa (125 ksi).

Break all sharp edges and treat with rust inhibitor oil for shipment.

All dimensions without tolerance stated to be ± 0.5

B

SECURING DISC

NAAMS CODE
R430001

NOTES & SPECIFICATIONS:

Material, steel

Washer to be painted safety yellow.

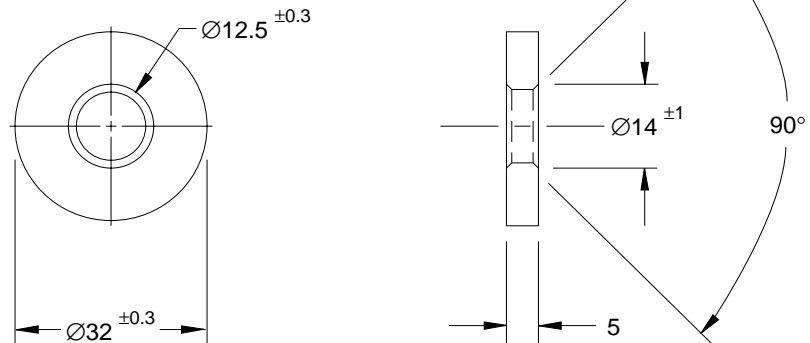

A

PAD STANDBY/LOCK PIN

(R42 SERIES)

A

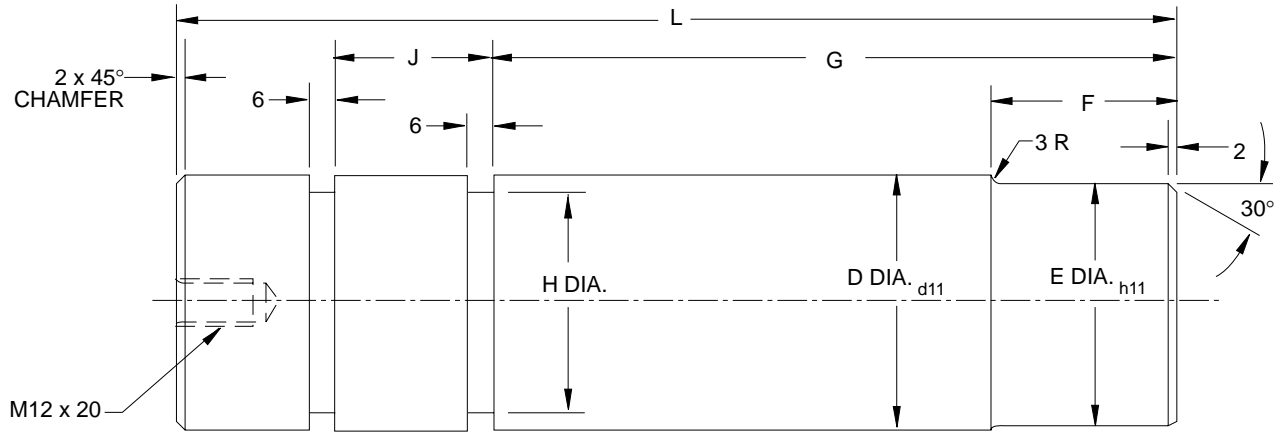

NAAMS CODE	PIN SIZE D	E	F	G	H	J	L
R422513	25	22	25	75	17	20	130
R423515	35	32	30	95	27	25	155
R425020	50	47	35	135	42	30	200
R426325	63	60	45	170	55	40	250

B

NOTES & SPECIFICATIONS:

Tensile strength 965 MPa. (140 ksi).

Yield strength 860 MPa (125 ksi).

Break all sharp edges and treat with rust inhibitor oil for shipment.

All dimensions without tolerance stated to be ±0.5